

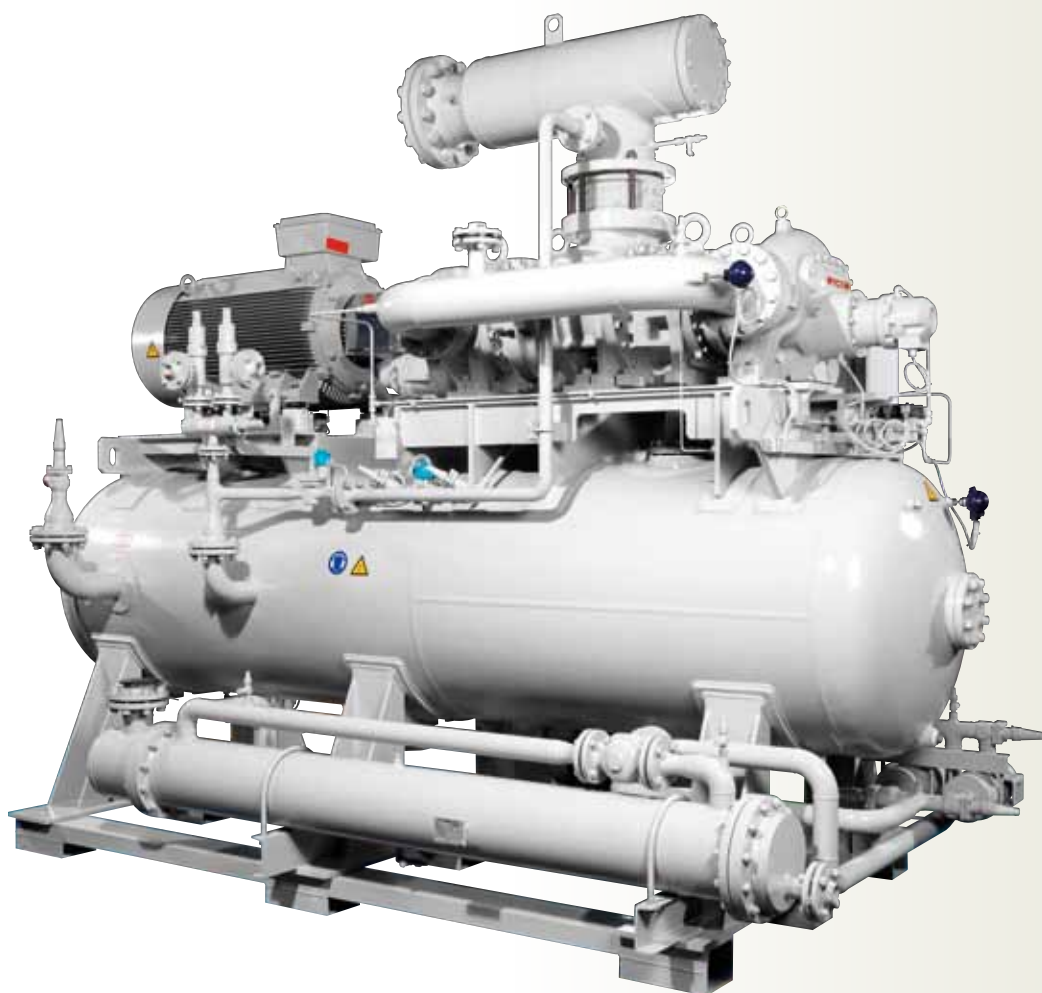

COMPOUND SCREW COMPRESSOR

C-SERIES

1612SSC - 3225LLC



The **Mayekawa compound screw compressor c-series**

is the power of one designed for the duty of two.

By combining the high and low stage rotors in one body it permits a 2 stage operation in one compressor. With two compressors in one you minimize your initial costs, footprint and maximize your output.

Applications are found in many areas through two stage systems, low temperature fields and sites with high compression ratios.

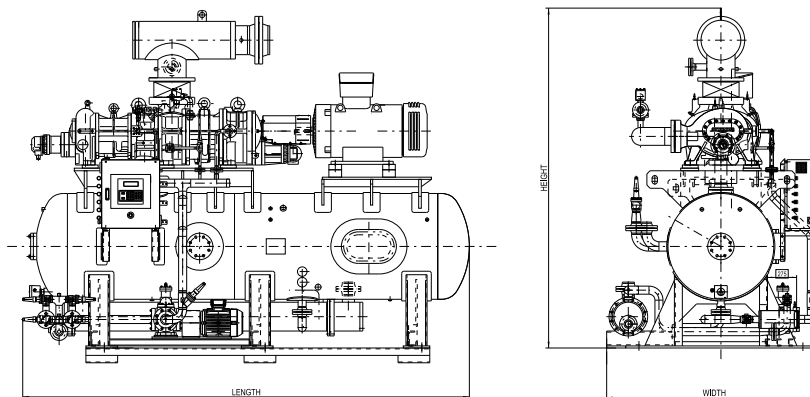

COMPOUND MODELS	LENGTH (mm)	HEIGHT (mm)	WIDTH (mm)	WEIGHT (kg)
N1612LSC-CPDDX-T	3500	2000	1200	4500
N2016LSC-CPDDX-T	3900	2400	1550	5500
N2520LSC-CPDDX-T	4300	3100	1900	7800
N3225LSC-CPDDX-T	4700	3300	2200	10500

Notes:

Heights are without transport profiles and with the suction strainers mounted. Transport arrangements should be made so that sufficient space is left for transport profiles which allow forklift handling. Suction strainers can be dismantled prior to shipping.

The weight includes a typical size IP23 drive motor.

Data can change depending on execution of the unit. Above data is approximative.

Classification following of C-Series

You can choose from many combinations

2 0 1 6 L S C - L B M

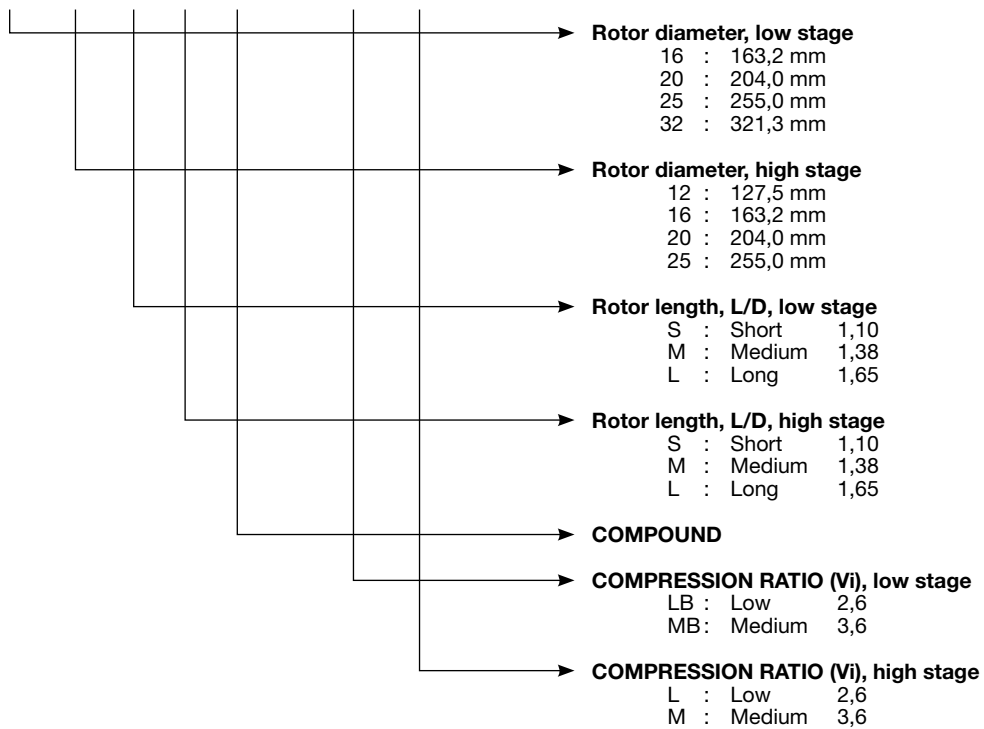

Representative reference of theoretical displacement

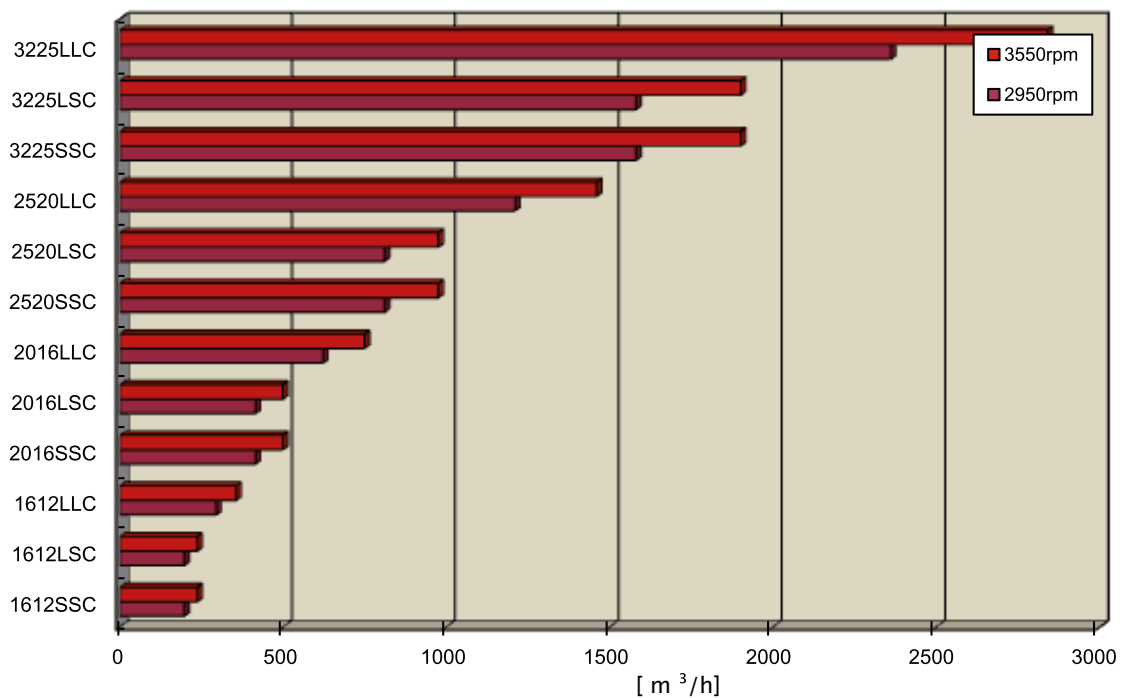

COMPRESSOR TYPE		1612	2016	2520	3225
DRIVE METHOD		DIRECT DRIVE			
OPERATING MODE		2 STAGE SYSTEM WITH DX LIQUID SUBCOOLERS (CPDDX) or 2 STAGE SYSTEM WITH OPEN FLASH VESSEL (SIDE LOAD) (CPDOF)			
CAPACITY CONTROL		HYDRAULIC CYLINDER SWITCHED BY 4 SOLENOID VALVES, STEPLESS REGULATION			
CAPACITY STEPS	LOW STAGE	0 - 100%	0 - 100%	0 - 100%	0 - 100%
	HIGH STAGE	100%	20 - 100%	20 - 100%	20 - 100%
CONNECTIONS (mm)					
LOW STAGE	SUCTION	125A	150A	250A	350A
	DISCHARGE	80A	100A	150A	200A
CONNECTIONS (mm)					
HIGH STAGE	SUCTION	80A	100A	150A	200A
	DISCHARGE	65A	80A	100A	150A
NET WEIGHT (kg)	LS	560	1140	2300	3440
	LM	580	1170	2350	3500
	LL	600	1200	2450	3650

DESIGN PARAMETERS	MIN	MAX
COMPRESSOR SPEED	1500 RPM	1612C 4500 RPM 2016C 4000 RPM 2520C 3600 RPM 3225C 3600 RPM
PRESSURES		
DISCHARGE PRESSURE (Pd)	/	20barG
SUCTION PRESSURE (Ps), INTERMEDIATE PRESSURE (Pm) (Ps)	-0,7 barG	6barG
PRESSURE DIFFERENCE PD-PS	/	20barG
OIL SUPPLY PRESSURE (Poil) SET PRESSURE Pd + 2 barG	Pd + 1 barG	Pd + 4barG
TEMPERATURES		
DISCHARGE TEMPERATURE (Td)	/	100°C (120°C)
OIL SUPPLY TEMPERATURE (Toil)	30°C	60°C

(*) Optional rotor 120° C
Above specifications are subject to change without notice

COMPRESSION SYSTEMS / PACKAGES

Mayekawa selects compressors to achieve the most optimum performance under the intended process conditions for compression system packages. Packages are proposed to satisfy the process requirements, -and plant conditions, and also to enable time and cost savings for installation at the customer's site.

ENGINEERING

Not only compression but a wide range of systems such as liquefaction, refrigeration, etc., can be quickly and accurately designed with Mayekawa's established engineering resources which utilizes many years of accumulated experience, and know-how, as well as the latest technology of CAD design and engineering software such as HYSYS, BJAC, etc.

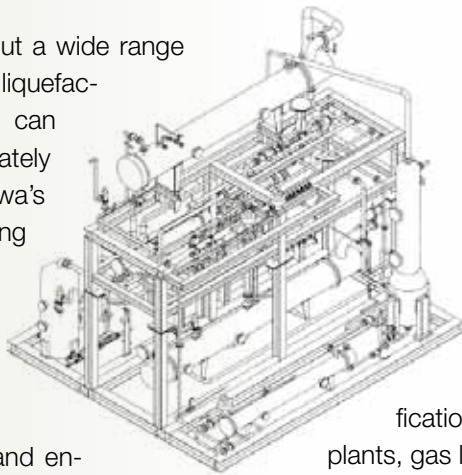

■ Driving system

Compressor drivers can be not only electric motors but also reciprocating engines or turbines utilizing various energy sources such as gas, liquid fuel, steam, etc..

■ Extended supply of complete plant

Provisioning complete plants associated with peripheral equipment is also possible, not just supply of simple packages with our core product, compressors. Mayekawa has successfully completed various kinds of plants requested by customers. For example, CO2 purification plants, gas turbine power generation plants, boil off gas plants, gas liquefaction, distillation and recovery plants, etc.

■ Oil separation system

Oil carry over can be reduced to almost the same level experienced with dry compressors by introducing the fine oil separation system developed through Mayekawa's broad experience with plants which cannot allow serious oil contamination like helium liquefaction or cryogenic systems.

COMPLIANCE TO CODES AND STANDARDS

Any applicable international codes, standards and customer's specific rules can be complied with as well as API standards so that the individual needs of customers throughout the world are satisfied.

CONTROL SYSTEM

A number of expert engineers with professional knowledge of compressor systems are ready to supply control systems compliant with international standards, including hazardous area applications. Also, instrument systems, PLC devices, communication methods to DCS or plant computer, etc., can be designed and supplied to accommodate all types of plant philosophies.

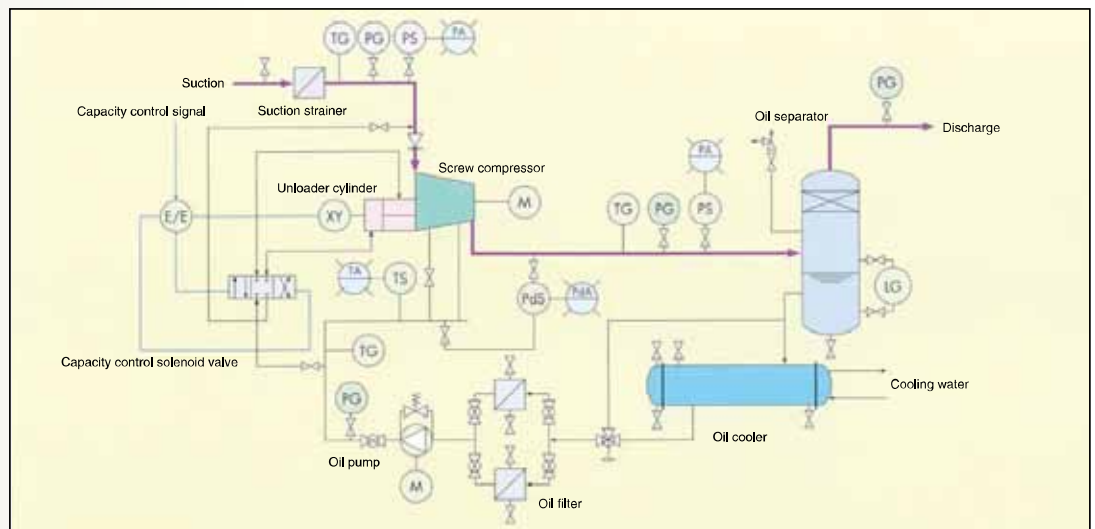

MAYEKAWA

MYCOM

WORLDWIDE

- 47 countries / 99 offices
- 11 production plants



MAYEKAWA EMEA Organization

ABU DHABI

Ali & Sons Business Center Office No. 201
Ali Khalfan Rashed Al Mutawa Al Dhahiri Bldg.
Plot no 29, Al Ain Road, Umm Al Nar
Tel. +971 2 5102151
Fax +971 2 5102571

DENMARK

Lindholm Havnevej 29, 5800 Nyborg
Tel. +45 31929000
Email: contact@mayekawa.dk

DUBAI

P.O. Box 61349, W-HOUSE
No. RA-08-UC05
Jebel Ali Free Zone Dubai, UAE
Tel. +971 4 8886363
Fax +971 4 8886373

EGYPT

New Cairo, 5th Settlement
North 90th St.
The 47th Building
Tel. +20 22 5062925
Fax +20 22 5032901

FRANCE (representative agent) Siège social

8, rue des Fontenelles
44140 Le Bignon
Tel. +33 1 30 582600
Fax +33 1 30 581937
<http://www.mayekawa.eu/fr>
E-mail: mayekawa.france@mayekawa.eu

South East Branch Office Refrigerant Division

Rue François Coli - Bâtiment H
33290 Blanquefort
Tel. +33 1 30 582600

West Branch Office Food Processing Division

20, Rue Ampère
22590 Pordic
Tel. +33 1 30589795
Fax +33 1 30581937

GERMANY Mayekawa Deutschland GmbH

Zum Buckesch 7a
48336 Sassenberg-Füchtorf
Tel. +49 (0) 5426 2989920

Vertrieb BRD/Österreich

Tel. +49 151 42628055
<http://www.mayekawa.de>
Email: info@mayekawa.de

HUNGARY

Mayekawa Hungary Engineering Kft

Köbányai út 10/A
2049 Diósd,
Tel. +36 23 545712
Fax +36 23 545715
<http://www.mayekawa.eu>
E-mail: hungary@mayekawa.eu

ITALY

Milan Office
Via Riccardo Lombardi 19/12
20153 Milano
Tel. +39 2 48929218
Fax +39 2 4531728

Bologna Office

Via Pradazzo 7 40012
Calerara di Reno
Tel. +39 51 726364
Fax +39 51 726804

MOROCCO

6, Allée des Cyprès
20250 Casablanca
Tel. +212 600 041241

POLAND

ul. Druskiennicka 8/10
60-476 Poznan
Tel. +48 61 8420738
Fax +48 61 8485837

SOUTH AFRICA

West End
Unit 3 Prime Park
Printers Way
Montague Gardens 7441
Tel. +27 21 5511434
Fax +27 86 5463618

SPAIN

Calle Montevideo 5, Nave 13 Pol.
Industrial Camporroso 28806
Alcala de Henares, Madrid Tel.
+34 91 8300392
Fax +34 91 8300397
<http://www.mayekawa.es>
E-mail: mayekawa@mayekawa.es

SWITZERLAND

Rosenbergstrasse 31
6300 Zug
Tel. +41 41 7268626
Fax +41 41 7268620
<http://www.mayekawa.ch>
E-mail: info@mayekawa.ch

TURKEY

Dünya Ticaret Merkezi
A/2 Blok Kat: 10 No. 325
Yeşilköy
Istanbul
Tel. +90 212 46536 31- 34
Fax +90 212 4653635

UKRAINE

Golosiiivska Street 17
Office 110
03039 Kiev
Tel. +38 (044) 251-46-62

UNITED KINGDOM

16 Oakhurst Gardens
DA7 5JP Bexleyheath, Kent
Tel. +44 1322 433558
Fax +44 1322 433164

Japan Head Office

3-14-15 Botan Koto-ku
Tokyo 135 8482, JAPAN
Tel. 81 3 3642 8181
Fax 81 3 3643 7094
E-mail e-public@mayekawa.co.jp

MAYEKAWA Europe nv/sa

Leuvensesteenweg 605
1930 Zaventem - Belgium
Tel. +32 2 7579075
Fax +32 2 7579023
<http://www.mayekawa.eu>
E-mail info@mayekawa.eu

Global web site <http://www.mayekawa.com/>